



**WORLD VALVE CO.,LTD**

---

## **Damper Valve**



**Product Information**



# Damper Valve

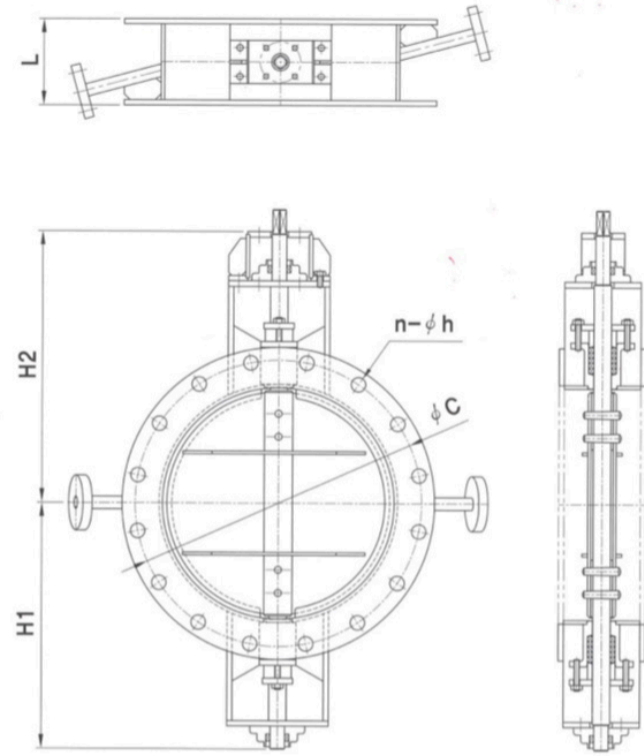
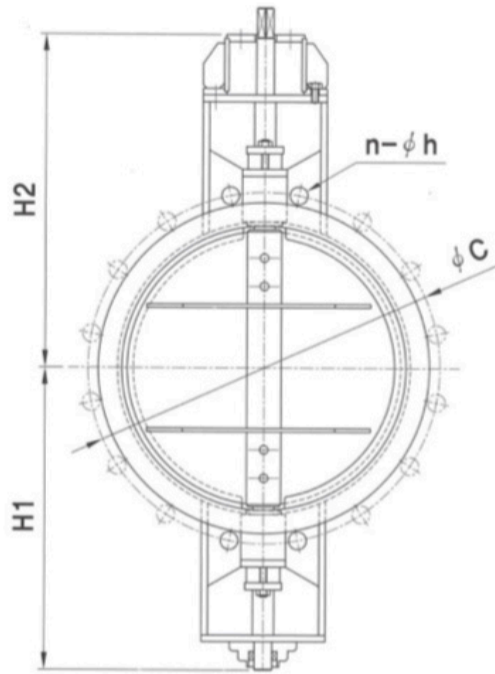

Materials		
No.	Part Name	Material
1.	Body	Mild steel, stainless steel
2.	Disc	Mild steel, stainless steel
3.	Stem	Mild steel, stainless steel
4.	Stopper	Mild steel, stainless steel

Specifications	
Size	50mm - 1000mm
Working Temperature	0°C - 500°C
Rating (Flange)	KS 5K/10K, JIS 5K/10K ANSI 125LB, 150LB, DIN-PN10, PN16
Operator	Manual lever operation Manual worm gear operation Single or double acting pneumatic actuator operation Hydraulic actuator operation Electric motor actuator operation

Dimensions					
Size	L	H1	H2	Flange JIS (5K)	
				φC	4 - φ19
80A	70	135	190	145	8 - φ19
100A	70	150	200	165	8 - φ19
125A	80	170	220	200	8 - φ19
150A	100	190	245	230	8 - φ23
200A	100	220	265	280	12 - φ23
250A	140	265	300	245	12 - φ23
300A	140	323	370	390	12 - φ23
350A	140	360	456	435	16 - φ25
400A	150	425	470	495	16 - φ25
450A	150	450	506	555	20 - φ25
500A	150	480	536	605	20 - φ27
550A	160	530	603	665	20 - φ27
600A	160	535	643	715	24 - φ27
650A	160	580	653	770	24 - φ27
700A	160	605	680	820	24 - φ33
750A	160	630	703	880	24 - φ33
800A	180	660	745	930	24 - φ33
900A	180	685	790	1030	24 - φ33
1000A	200	710	835	1130	28 - φ33